

JOB UNIT TAG NO. ENGINEER CONTRACTOR	HOFFMAN SPECIALTY REPRESENTATIVE ORDER NO. SUBMITTED BY APPROVED BY DATE DATE DATE
---	---

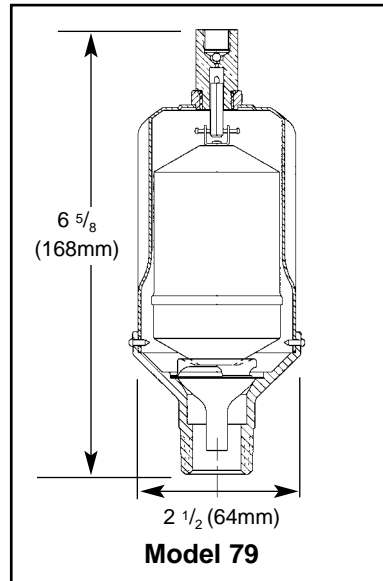

Model 78 and 79 Water Main Vent Valve

Capacities

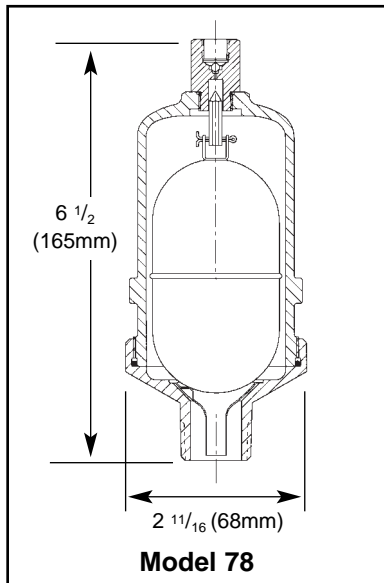
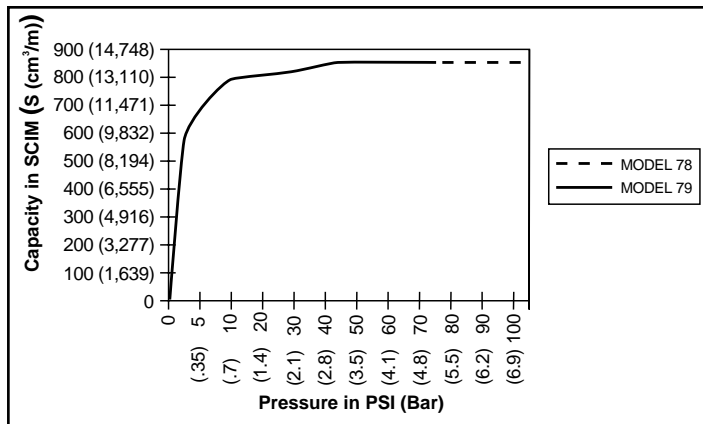

Materials of Construction

Part	Specifications	
	Model 78	Model 79
Shell	Cast Brass	Brass Stamping
Base	Cast Brass	Brass Forging
Float	Stainless Steel	Brass
Seat	Brass	Brass
Pin	Stainless Steel	Brass

Ratings

Model	NPT Inlet Size in. (mm)	NPT Outlet Size in. (mm)	Maximum Operating Pressure psig (bar)	Maximum Hydrostatic Pressure psig (bar)	Maximum Operating Temperature °F (°C)
78	3/4 (20) male	1/8 (4)	150 (10.3)	450 (31.1)	250 (121)
79	1/2 (15) female	1/8 (4)	75 (5.2)	200 (13.8)	250 (121)
	3/4 (20) male				