

Flow Switches – Liquid

Series FS4-3 (for specified models) General Purpose Liquid Flow Switches

- Universal design serves the widest variety of applications
- For starting or stopping electrically operated equipment such as signal lights, alarms, motors, automatic burners, metering devices and others
- Replacement for Johnson Controls flow switch Model F61KB-11
- 1" (25mm) NPT
- Two electrical knock-outs allows connection from either end
- Sensitivity adjusting screw makes flow adjustment easy
- Single pole, double throw snap switch
- Hardened stainless steel bearings minimize friction
- Sealed Monel bellows
- Four stainless steel paddles included - 1", 2", 3" & 6" (25, 50, 80, & 150mm) **NEW**
- Optional features
 - Time delay (5 or 20 seconds)
 - Two SPDT switches to make or break two separate circuits
 - Reinforced paddles
 - Materials of construction suitable for corrosive liquids
 - Sprinkler service - Model FS4-3F only
 - BSPT threads
- Minimum temperature (fluid or ambient) 32°F (0°C)
- Maximum temperature 300°F (149°C)
- Maximum pressure 150 psi (10.5 kg/cm²)

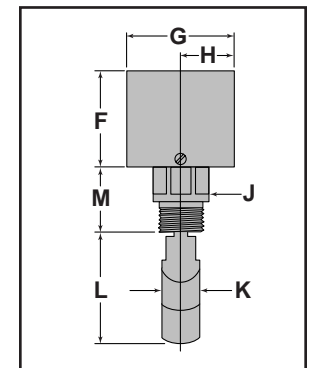
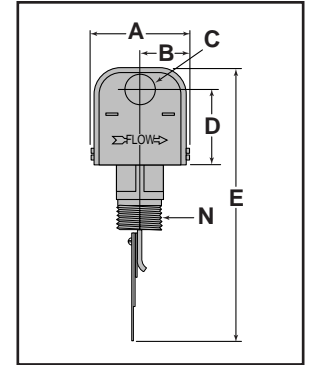

Electrical Ratings

Voltage	Motor Switch Rating (Amperes)		Pilot Duty
	Full Load	Locked Rotor	
120 VAC	7.4	44.4	125 VA at 120 or 240 VAC 50 or 60 cycles
240 VAC	3.7	22.2	

Dimensions, in. (mm)

A	B	C	D	E	F	G
3 (76)	1½ (38)	7⁄8 (22)	27⁄32 (56)	87⁄16 (211)	215⁄16 (75)	33⁄8 (86)

H	J	K	L	M	N NPT
111⁄16 (43)	17⁄16 (37)	11⁄8 (29)	37⁄16 (87)	21⁄16 (52)	1 (25)

Flow Switches – Liquid (continued)

Series FS4-3 (continued) General Purpose Liquid Flow Switches

Flow Rates

Pipe Size NPT in. (mm)	Settings	Mode of Operation		Max. Flow Rate gpm (lpm) w/o Paddle Damage
		Flow gpm (lpm)	No Flow gpm (lpm)	
1 (25)	Factory or Minimum	6 (22.7)	3.6 (13.6)	27 (102.2)
	Maximum	10.2 (38.6)	9.2 (34.8)	
1¼ (32)	Factory or Minimum	9.8 (37.1)	5.6 (21.2)	47 (177.9)
	Maximum	16.8 (63.6)	15 (56.8)	
1½ (40)	Factory or Minimum	12.7 (48.1)	7 (26.5)	63 (238.5)
	Maximum	23 (87.1)	19.5 (73.8)	
2 (50)	Factory or Minimum	18.8 (71.2)	9.4 (35.6)	105 (397.4)
	Maximum	32.8 (124.1)	24 (90.8)	
2½ (65)	Factory or Minimum	24.3 (92)	11.6 (43.9)	149 (564)
	Maximum	42.4 (160.5)	37.5 (141.9)	
3 (80)	Factory or Minimum	30 (113.6)	12 (45.4)	230 (870.6)
	Maximum	52.1 (197.2)	46.1 (174.5)	
4 (100)	Factory or Minimum	39.7 (150.3)	19.8 (74.9)	397 (1502.7)
	Maximum	73.5 (278.2)	64.2 (242)	
5 (125)	Factory or Minimum	58.7 (222.2)	29.3 (110.9)	654 (2415.4)
	Maximum	115 (435.3)	92 (348.2)	
6 (150)	Factory or Minimum	79.2 (300)	39.6 (150)	900 (3406.5)
	Maximum	166 (628.3)	123 (465.6)	

Values are ± 10%

Ordering Information

Model Number	Part Number	Description	Weight lbs. (kg)
FS4-3	114400	General purpose flow switch	1.9 (0.9)
FS4-3J	114610	FS4-3 w/BSPT connections	1.9 (0.9)
FS4-3-RP	114650	FS4-3 w/SSreinforced paddles	2.3 (1.0)
FS4-3Z	114410	FS4-3 w/ANSI terminal connections	1.9 (0.86)
FS4-3A	114450	FS4-3 w/tamper-proof cover screws	2.0 (0.9)
FS4-3C	114451	FS4-3 w/trimmed paddles	1.9 (0.9)
FS4-3D	114450	FS4-3 w/2 SPDT switches	2.3 (1.0)
FS4-3S	114641	FS4-3 w/SS body, monel bellows	1.9 (0.9)
FS4-3SJ	176216	FS4-3S w/BSPT connections	1.9 (0.9)
FS4-3DS	114642	FS4-3S w/2 SPDT switches	3.3 (1.5)
FS4-3-5R	114405	FS4-3 w/5 second DOB	2.3 (1.0)
FS4-3-20	114425	FS4-3 w/20 second DOM	2.3 (1.0)
FS4-3-5R	114405	FS4-3 w/5 second DOB	2.3 (1.0)
FS4-3J-E	114611	FS4-3J-CE conformance rated	1.9 (0.9)
FS4-3D-E	114552	FS4-3D-CE conformance rated	1.9 (0.9)
FS4-3S-E	114646	FS4-3S-CE conformance rated	1.9 (0.9)
FS4-3F	114625	FS4-3 for sprinkler service	1.9 (0.9)
FS4-3FCAN	114626	FS4-3 for sprinkler service (Canada)	2.3 (1.0)
FS4-3F-20	114635	FS4-3F w/20 second DOM	2.3 (1.0)
FS4-3DF	114555	FS4-3F w/2 SPDT switches	2.3 (1.0)
FS4-3DF-20	114640	FS4-3F w/20 second DOM, 2 SPDT switches	3.3 (1.50)

See page 186 for CE Conformance information

NOTE: DO NOT USE LIQUID FLOW SWITCHES ON SYSTEMS WITH FLOW GREATER THAN 10 FEET (3M) PER SECOND.

For Model FS4-3F & FS4-3DF

NPT Pipe Size In. (mm)	Paddle to use Length (see illustration)	TEE Size
1" (25)	1 ^{11/32} " as furnished (only)	1" x 1" x 1" NPT Tee
1¼" (32)	Trim 1½" pipe size paddle with template	1¼" x 1¼" x 1" NPT Tee (Paddle must be bowed for insertion into 1¼" tee)
1½" (40)	2 1/16" as furnished (only)	1½" x 1½" x 1" NPT Tee (Paddle must be bowed for insertion into 1½" tee)

NOTE: ONLY LISTED PIPE SIZES MEET UL REQUIREMENTS FOR FIRE SPRINKLER SYSTEMS.

Flow Switches – Liquid

Series FS4-3T (for specified models) General Purpose Liquid Flow Switches

- For starting or stopping electrically operated equipment such as signal lights, alarms, motors, automatic burners, metering devices and others
- In-line configuration eliminates need for a pipe tee
- Sizes available
 - 3/4" (20mm) NPT
 - 1" (25mm) NPT
- Paddles available for low, medium or high flow
- Two electrical knock-outs allows connection from either end
- Sensitivity adjusting screw makes flow adjustment easy
- Single pole, double throw snap switch
- Hardened stainless steel bearings minimize friction
- Sealed Monel bellows
- Minimum temperature (fluid or ambient) 32°F (0°C)
- Maximum temperature 300°F (149°C)
- Maximum pressure 150 psi (10.5 kg/cm²)

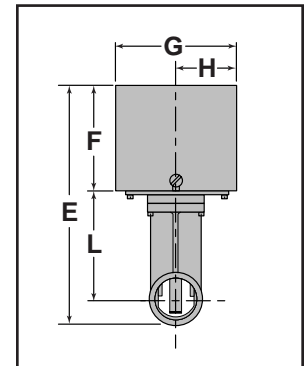
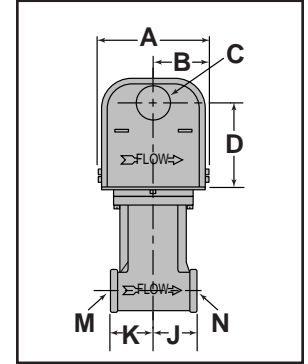

Electrical Ratings

Voltage	Motor Switch Rating (Amperes)		Pilot Duty
	Full Load	Locked Rotor	
120 VAC	7.4	44.4	125 VA at 120 or 240 VAC 50 or 60 cycles
240 VAC	3.7	22.2	

Dimensions, in. (mm)

A	B	C	D	E	F	G
3 (76)	1½ (38)	7/8 (22)	2 7/32 (56)	6 7/8 (175)	2 15/16 (75)	3 3/8 (86)
H	J	K	L	M NPT	N NPT	
1 11/16 (43)	1 5/16 (33)	1 1/8 (29)	3 1/16 (78)	3/4 or 1 (20 or 25)	3/4 or 1 (20 or 25)	

Flow Switches – Liquid (continued)

Series FS4-3T (continued)

General Purpose Liquid Flow Switches

Flow Rates

Pipe Model Number	Size NPT in. (mm)	Settings	Mode of Operation		Max. Flow Rate gpm (lpm) w/o Paddle Damage
			Flow gpm (lpm)	No Flow gpm (lpm)	
FS4-3T1-3/4	3/4 (20)	Factory or Minimum	4.4 (16.7)	2.6 (9.8)	16.62 (62.9)
		Maximum	10.5 (39.7)	9.8 (37.1)	
FS4-3T2-3/4	3/4 (20)	Factory or Minimum	3.7 (14)	2.2 (8.3)	
		Maximum	8.9 (33.7)	8.3 (31.4)	
FS4-3T3-3/4	3/4 (20)	Factory or Minimum	2 (7.6)	1.2 (4.5)	
		Maximum	4.5 (17)	4.1 (15.5)	
FS4-3T1-1	1 (25)	Factory or Minimum	5 (18.9)	3.2 (12.1)	27 (102.2)
		Maximum	11.5 (43.5)	11 (41.6)	
FS4-3T2-1	1 (25)	Factory or Minimum	4.8 (18.1)	2.9 (11)	
		Maximum	10.1 (38.2)	9.4 (35.6)	
FS4-3T3-1	1 (25)	Factory or Minimum	2 (7.6)	1.2 (4.5)	
		Maximum	4.5 (17)	4.1 (15.5)	

Values are ± 10%

Ordering Information

Model Number	Part Number	Description	Weight lbs. (kg)
FS4-3T1-3/4	114800	3/4" (20mm) NPT body - high flow rate	3 (1.4)
FS4-3T2-3/4	114900	3/4" (20mm) NPT body - medium flow rate	3 (1.4)
FS4-3T3-3/4	115000	3/4" (20mm) NPT body - low flow rate	3 (1.4)
FS4-3T1-1	115100	1" (25mm) NPT body - high flow rate	3 (1.4)
FS4-3T2-1	115200	1" (25mm) NPT body - medium flow rate	3 (1.4)
FS4-3T3-1	115300	1" (25mm) NPT body - low flow rate	3 (1.4)
FS4-3T3-3/4-E	115001	FS4-3T3-3/4 -CE conformance rated	3 (1.4)
FS4-3T3-1-E	115301	FS4-3T3-1 -CE conformance rated	3 (1.4)

See pages 186 for CE conformance information

NOTE: DO NOT USE LIQUID FLOW SWITCHES ON SYSTEMS WITH FLOW GREATER THAN 10 FEET (3M) PER SECOND.